

Product Line

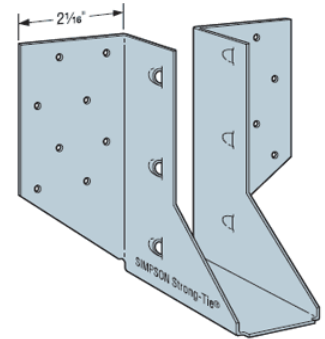

Timber Truss Structural components utilize [Simpson Strong-Tie](#) metal connectors and hardware. Simpson works with its partners to develop products supporting green building and is “involved in environmental conscious activities both internally and externally.”

- All Simpson Structural hangers have 30% recycled content.
- In 2006 Simpson recycled over 10 million pounds of scrap steel for use in other steel applications.
- Simpson has created a ledger connector system specifically for the ICF industry.
- Painted products utilize non toxic processes to eliminate the volatile organic emissions associated with solvent-based paints.
- [Simpson’s Environmental Statement](#)



As one of the highest quality door manufacturers, [Therma-Tru](#) is committed to the responsible use of natural resources in creating a high-performance entry and patio door system.

- Most Therma-Tru fiberglass door systems are Energy Star rated
- Doors are filled with CFC-free polyurethane foam to offer five times more insulation than wood
- Therma-Tru Doors are designed as a complete system with components that work together to form the tightest seal possible. This creates an energy efficient envelope for the home, stabilizing the interior temperature and decreasing energy costs.



Product Line



[Atrium](#) high performance windows can provide energy efficient and maintenance free products to help you lower energy bills. Most of the windows Atrium manufactures are Energy Star compliant in all fifty states.

- Lead free non petroleum based pvc vinyl.
- 24 to 28 percent of the raw window glass material is reclaimed glass from internal or external sources.
- Warm edge sealant system insulates up to 90 percent better than aluminum spacer bars.

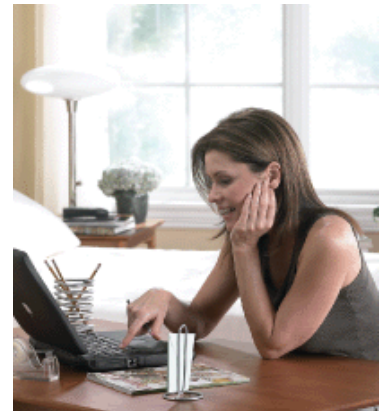

[Weather Shield](#) is committed to building an exceptional product line of windows and doors while easing its burden on the environment. Weather Shield [ProShield](#) product line of vinyl-clad windows and patio doors has received the first independent certification by the Scientific Certification Systems for recycled material content.

- [Zo-e-shield](#) glass system can save 15% to 30% of your annual heating and air conditioning costs over traditional double paned windows. With up to 3 layers of glass and multiple Low E coating Zo-e-shield is unlike any glass system in the world.
- Most Weather Shield products are Energy Star rated.
- SCS Certification allows the Pro-Shield product line to contribute towards the achievement of LEED recycled content points.
- The thermal performance of Weather Shield products is rated, certified and labeled by the National Fenestration Rating Council (NFRC).



Product Line



Dow has combined structural shear bracing, insulation performance and a water resistive barrier in one light weight product. [Dow STYROFOAM SIS Brand Structural Insulated Sheathing](#) lowers installed costs by allowing the builder to install these three key components in one easy step.

- 80% post consumer recycled helps contribute to LEED MR-4 Recycled Content.
- Lightweight, less than 16 lbs. per 4'x8' board at 1/2" thick.
- High R-value (R-5.5 at 1").
- Reduces thermal bridging across wall studs and headers.
- 15 year limited thermal warranty.



Contact your local sales office today for pricing and availability.